

Garlock Live Load Data Sheet

END USER: _____
VALVE TAG NUMBER: _____

Valve Manufacturer: _____
 Valve Figure Number: _____
 Valve Size: _____
 Valve Rating: _____
 Valve Type: _____

Actuator Type: _____
 System / Location: _____
 System Temperature: _____ F
 System Pressure: _____ psi
 System Media: _____

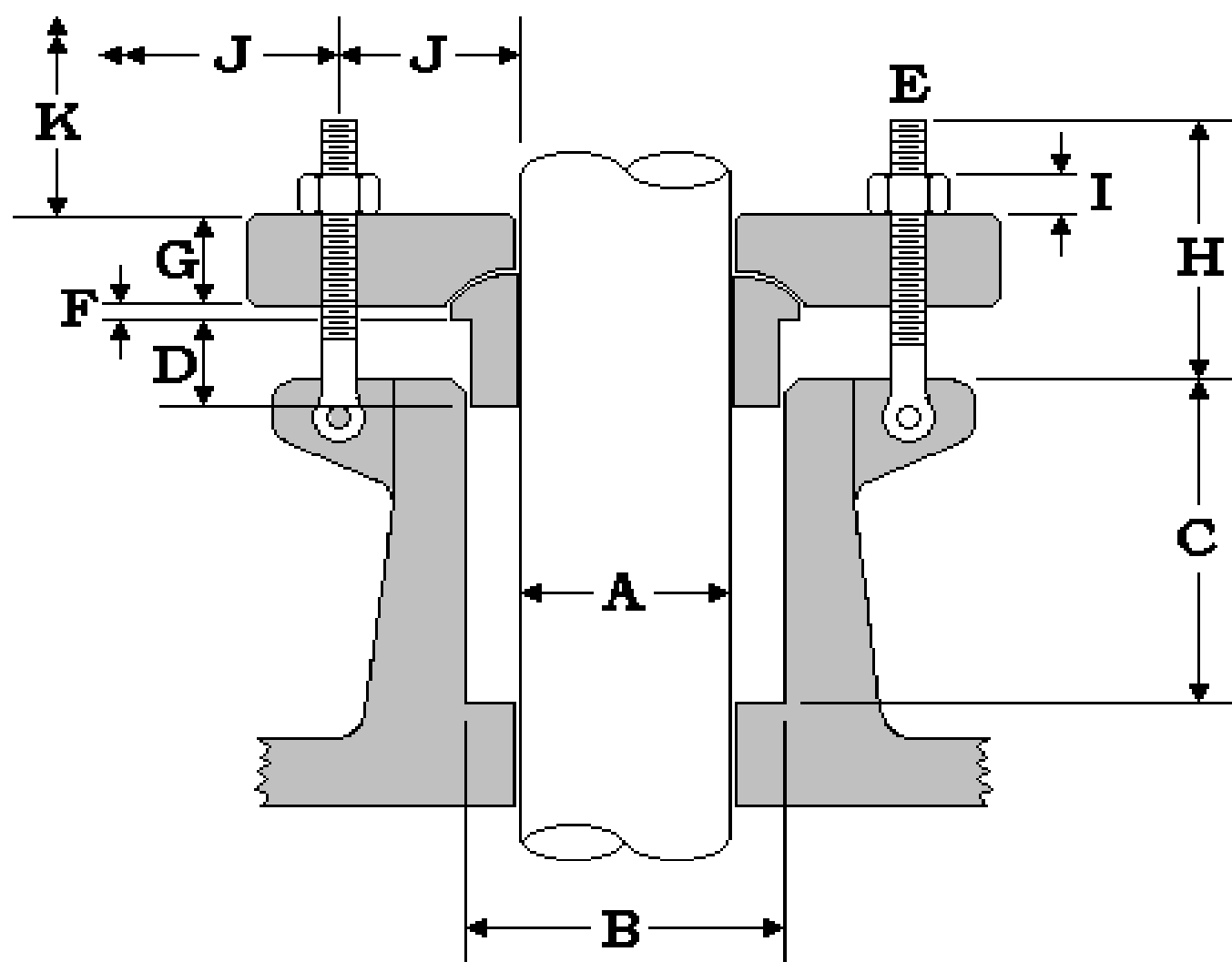

(A) Stem Diameter: _____
 (B) Stuffing Box Bore: _____
 (C) Stuffing Box Depth: _____
 (D) Gland Follower Length: _____
 Number Of Gland Studs: _____
 (E) Gland Stud Diameter: _____

(F) Follower Shoulder: _____
 (G) Gland Thickness: _____
 (H) Usable Stud Length: _____
 (I) Gland Nut Thickness: _____
 (J) Radial Clearance: _____
 (K) Height Clearance: _____

*Is a Lantern ring to be used in this valve / packing set? YES NO

Data Taken By: _____